

The Nuclear-Solar hybrid system concept development

In Woo Son^a, Jeong Ik Lee^{a*}

^aDept. Nuclear & Quantum Eng., KAIST, 373-1, Guseong-dong, Yuseong-gu, Daejeon, 305-701, Republic of Korea

*Corresponding author: jeongiklee@kaist.ac.kr

1. Introduction

A self-sufficient micro-grid is gaining attention due to reduction in transmission costs. Micro-grids in islands or remote regions require a base energy source that does not require frequent refueling due to the high fuel transportation cost. In this regard, SMR (Small Modular Reactor) that is cost-effective and does not require refueling for long time is suitable as a base energy source for the region. However, conventional SMRs using bulky steam generation systems are not preferred in terms of system transportation. To solve this problem, the KAIST research team developed the KAIST MMR (Micro Modular Reactor) by combining a SMR with a sCO₂ power cycle that has a relatively small volume of components and has higher efficiency than a steam power generation system at moderate temperature [1].

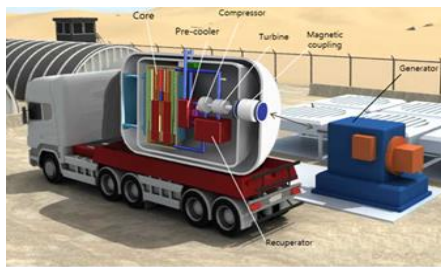

Fig 1. Concept diagram of the KAIST MMR [1]

The MMR consists of a power system and a core system packed in one module, which has the advantages that can be transported by truck or ship, and it is designed to meet electricity demand in isolated regions. However, in the case of nuclear power, since the initial capital cost is expensive while fuel cost is low, the capacity factor should be high to have good economy. If renewable energy source can supply peak demand in the region while MMR operates as in baseload, the combined system can meet the electricity demand of an isolated region with good economy. As a renewable energy source to be combined with MMR, a Concentrated Solar Power (CSP) system was selected which is a solar technology that collects solar irradiation through mirrors to heat the heat transfer fluid to operate the power cycle at high temperature. The reason is that CSP can operate in the temperature range of MMR (400-600°C) and compensate for shortcomings of each other through thermal integration of both systems. CSP has the disadvantage that it requires a large land area, but this can be resolved by combining with MMR. Therefore, in this study, the concept design of a hybrid system combining MMR and CSP is conducted.

2. Methods and Results

2.1 Electricity demand and DNI of the target region

The target region where the hybrid system is to be installed is a micro-grid in an island or remote area. The micro-grid generally means a grid having a capacity under 50MW in total. Therefore, as a result of investigating the regions that satisfy the conditions, it was found that various islands in S. Korea meet the conditions as summarized in the table. Therefore, electricity demand in the target region is selected using data from S. Korea. However, it is noted that the hybrid system is not designed to meet electricity demand of a specific region in S. Korea.

Table1. Power generation capacity of the various islands of Korea

Target island	Power generation capacity
Baengnyeong	15MW
Yeonpyeong	7.7MW
Ulleung	19.2MW

Korea's electricity demand data from March 1, 2018 to February 28, 2019 was obtained from KPX (Korea Power Exchange). In order to use the electric demand data in Korea, the two characteristics of the electricity demand data were calculated as follows. The base to peak ratio is the ratio of the highest daily electricity demand to the lowest daily electricity demand and peak time is the time of the peak electrical demand during the day.

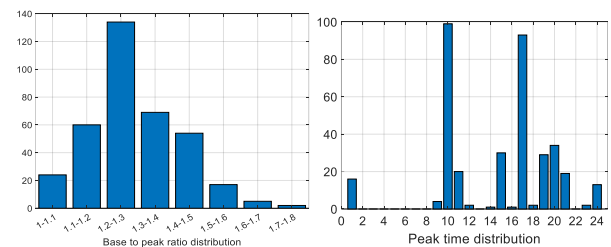

Fig 2. The characteristics of the Korea electric demand data

In this study, the base electricity demand in the target region was selected as 12 MWe because the MMR of the hybrid system is in charge of the baseload and the CSP meets the peak-load. As a result, the peak electricity demand in the target area is calculated as 21MWe using the largest base to peak ratio. In addition, considering Korea's electricity reserve ratio of 122% in 2018 [2], the electricity demand in the target area was determined by scaling the highest electricity demand in Korea to 25.62

MWe throughout the year. The following shows the electricity demand in the target area for one year.

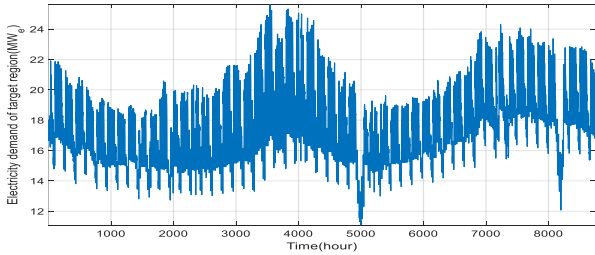

Fig 3. The electricity demand in the target area for one year

Likewise, the DNI (Direct Normal Irradiation) of the target region was selected using DNI data from S. Korea. DNI is the data needed to calculate the CSP power curve. To theoretically calculate the DNI of S. Korea, the method proposed in Zhang's work was used [3]. In order to theoretically obtain DNI by this method, the latitude, longitude, and the monthly average of H (The daily total radiation obtained from the registered Measurements) of the target area are required. The DNI of the target region was theoretically calculated using the average values of latitude, longitude, and H data for 22 points across S. Korea surveyed by the Korea Meteorological Administration [4]. The figure below is the seasonal average DNI value of the calculated target area.

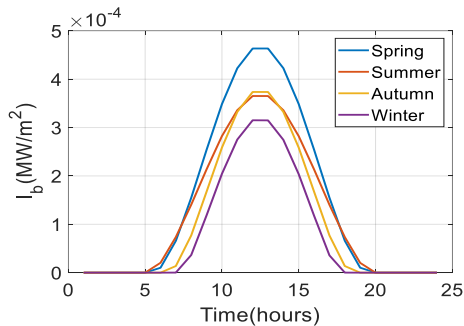

Fig 4. The seasonal average DNI of the target area

2.2 Thermal energy storage type and storage medium

As a thermal energy storage system, two tank storage systems that are commercially available, cost-effective, and operable in the MMR operating temperature range (400-600°C) were selected [5]. Solar salt is selected as the storage medium of the hybrid system because it is the most commonly used molten salt and is chemically stable and shows an excellent thermal performance [5].

2.3 Design of the Cycle layout for the hybrid system

The hybrid system uses the sCO₂ power cycle, and according to Ahn's work [6], the highest efficiency cycle layout among several layouts was confirmed to be the recompression cycle. Therefore, the cycle layout of the hybrid system was selected as the recompression cycle layout. However, since the hybrid system has two heat sources, CSP and MMR, the cycle layout of

recompression with reheating is selected as the basic cycle layout.

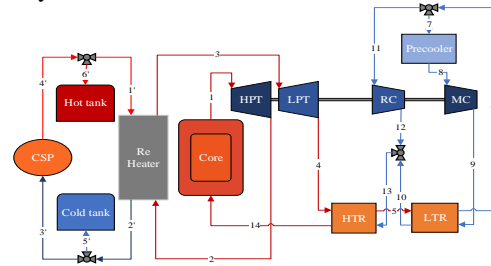

Fig 5. Recompression with reheating cycle layout of the hybrid system

To find the optimum point of the cycle, cycle optimization must be performed. Therefore, the cycle boundary conditions were selected as follows: 1. The CO₂ outlet temperature on the re-heater was selected as 570°C considering the temperature limit of 585°C in the solar salt [7], 2. The efficiency of the turbine and compressor is selected as 85% and 80%, respectively referring to the design conditions of the US DOE STEP project and the Shouhang Dunhuang 10MWe CSP plant [8, 9].

The cycle design was optimized using the KAIST-CCD code under the above conditions. KAIST-CCD code is an in-house code developed by the KAIST research team based on MATLAB [10]. The cycle design optimization results are shown below. As a result of optimization, when Pr = 2.24, FSR = 0.66, HPTPR = 1.42, the cycle efficiency is 41.63%.

Table 2. Cycle design fixed value and optimization variables

Cycle design fixed value			
Max P	20Mpa	MMR heat	36.2MWth
Min T	35°C	Reheat	27.15MWth
MMR outlet T	550°C	Turbine efficiency	85%
Re-heater outlet T	570°C	Compressor efficiency	80%
HTR, LTR effectiveness	0.95	Component pressure drop (Kpa)	100-150
Optimization variables			
Pressure ratio	Flow split ratio	High pressure turbine pressure ratio	

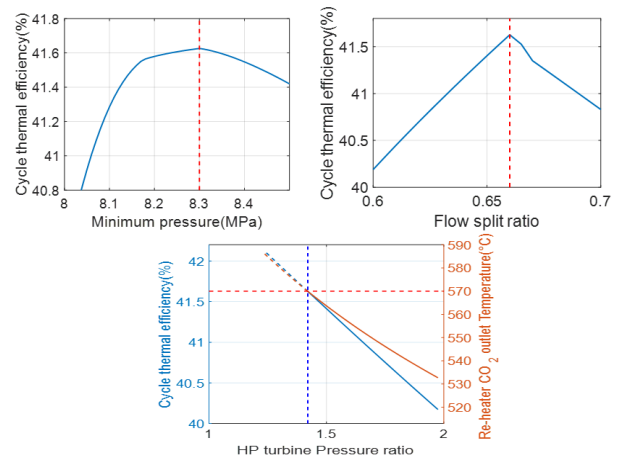

Fig 6. Optimization result of the cycle of the hybrid system

2.4 Turbomachinery design

The turbomachinery of the hybrid system was designed with KAIST-TMD code based on MATLAB which is developed by the KAIST research team. The code can estimate the geometry and performance of the turbomachinery at the design and off-design points. The description of the code is in the following reference [11]. The table below shows the results of the turbomachinery design.

Table 3. Design results of the turbomachinery of the hybrid system

	High-pressure turb.	Low-pressure turb.	Main comp.	Re-comp.
Work (MW)	21.93	16.70	5.25	6.61
Pressure ratio	1.58	1.42	2.4	2.37
Efficiency (%)	85.13	85.07	80.01	80.03
T_{in} (°C)	550	570	35	70.16
P_{in} (Mpa)	19.75	13.75	8.3	8.4
P_{out} (Mpa)	13.9	8.70	20	19.90
mass flow rate(kg/s)	361.53	361.53	232.08	122.9

2.5 Heat exchanger design

The heat exchanger of the hybrid system was designed through the KAIST-HXD code. This code was developed in MATLAB environment and can perform PCHE design for the sCO₂ power system application. The code is described in the following reference [12]. Using the KAIST-HXD code, the heat exchangers of the hybrid system were designed as follows.

Table 4. Design results of the heat exchangers of the hybrid system

Parameters	HTR	LTR	Pre-cooler	Re-heater
Type	PCHE (Zigzag)	PCHE (Zigzag)	PCHE (Zigzag)	PCHE (Straight)
Heat load [MW]	138.2	54.2	36.6	27.2
Hot Avg. Re #	35900	80400	81600	700
Cold Avg. Re #	58100	42400	4300	15400
ΔP_{hot} [kPa]	150	150	100	13
ΔP_{cold} [kPa]	100	100	100	150
Active Length [m]	0.82	1.47	0.68	1.37
Active Volume [m ³]	2.15	2.42	0.70	5.19

2.6 Quasi-steady-state of the hybrid system

To evaluate the annual performance of the hybrid system, it is necessary to analyze the off-design performance of the hybrid system under part-load operation. KAIST-QCA is a MATLAB-based in-house code developed by the KAIST research team for quasi-steady-state analysis [13]. To use the KAIST-QCA code, turbomachinery and heat exchanger design values are used. The part-load situation of the hybrid system is a condition where only the mass flow rate decreases while

the hot and cold temperatures of the solar salt of the re-heater is maintained. In the part-load operation, the system control strategy is the bypass control and inventory tank control to achieve higher efficiency, which controls the mass flow rate of the components or overall cycles as shown in the figure below.

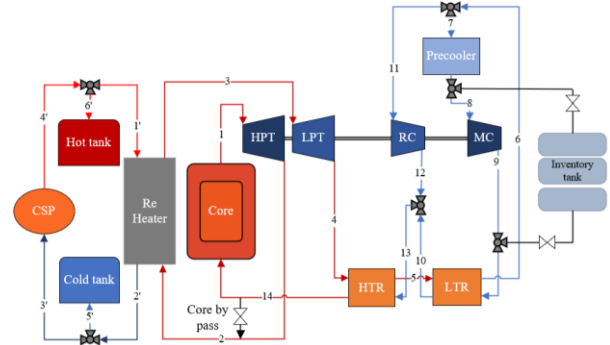

Fig 7. Core bypass and Inventory tank control for part-load operation

For the cycle to have higher efficiency in a part-load situation, the components should not deviate from the design point. Therefore, the main purpose of the control strategy was to maintain the main compressor inlet temperature 35°C and the MMR CO₂ outlet temperature 550°C. Therefore, through the core bypass, the outlet temperature of the MMR was maintained, and the outlet and inlet of the inventory tank were respectively connected to the compressor inlet and outlet, maintaining the inlet temperature of the main compressor, and adjusting the entire mass flow rate of the cycle so that the cycle stays at the most efficient operating conditions.

Therefore, the total work and efficiency for the re-heater part-load condition of the hybrid system were calculated through the control strategy described above.

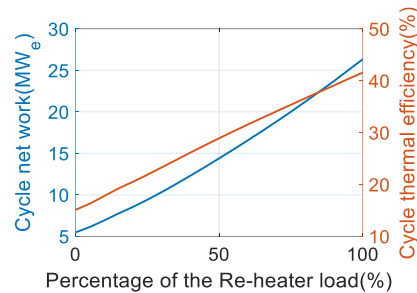

Fig 8. The total work and efficiency for the re-heater part-load operation of the hybrid system

2.7 The Evaluation of the hybrid system

To evaluate the hybrid system, the capacity factor and electrical demand fulfillment rate of the hybrid system must be calculated for one year of electric demand in the target area. The capacity factor is defined as the ratio of the electricity actually the system produced to the maximum electricity the system can produce over a given period. The electricity demand fulfillment rate is the rate of how long the hybrid system can meet the electricity demand for a given time. Capacity factor and

electricity demand fulfillment rate are variables of TES capacity and solar field area of the hybrid system.

The following assumptions were made to calculate the solar field area of the hybrid system: 1. The total heat of CSP calculated for the target region over 1 year is equal to the total reheat corresponding to the electric demand of the target region for 1 year. 2. After one year, the amount of TES storage medium is the same as the initial value.

First, the reheat required for the electricity demand of the target area for 1 year was calculated by using the QCA results with a 1-hour interval.

$$Q_{reheat,ED} = \text{fun}_{QCA}(\text{Electricity demand})$$

To find the total required reheat, the reheat corresponding to the calculated hourly electrical demand is integrated over one year.

$$\int_0^{365 \times 24} Q_{reheat,ED} dt = Q_{Total\ reheat,ED}$$

The CSP heat generated per hour is defined as:

$$Q_{CSP} = DNI \times \eta_{hf} \times \eta_{rec} \times A_{sf}$$

Where η_{hf} is heliostat field efficiency, η_{rec} is receiver efficiency and A_{sf} is solar field area. Therefore, the CSP heat generated over one year is calculated as follows.

$$\int_0^{365 \times 24} Q_{CSP} dt = Q_{Total,CSP} = \int_0^{365 \times 24} DNI dt \times \eta_{sf} \times \eta_{rec} \times A_{sf}$$

Since the reheat required corresponding to electricity demand for one year was calculated before, The CSP solar field area to generate the reheat required for one year equal to the heat produced by the CSP is calculated as follows:

$$Q_{Total\ reheat,ED} = Q_{Total,CSP}$$

$$A_{sf} = \frac{Q_{Total\ reheat,ED}}{\int_0^{365 \times 24} DNI dt \times \eta_{sf} \times \eta_{rec}}$$

Since the required solar field area was calculated, the capacity factor and electrical demand fulfillment rate are a function of TES capacity. The figure below is a graph of two variables.

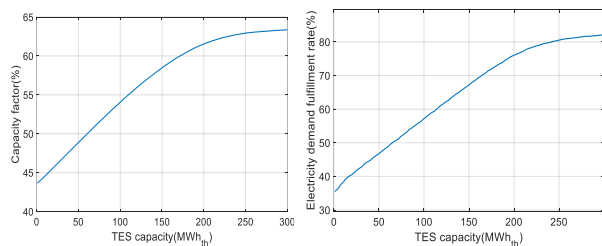

Fig 9. The capacity factor and electrical demand fulfillment rate according to TES capacity

3. Conclusions

In this study, the concept development of the nuclear-solar hybrid system was conducted. The nuclear-solar hybrid system has the advantage of reducing the large solar field area, which is a disadvantage of CSP while maintaining the high capacity factor of nuclear power. In addition, it does not require refueling making it suitable as an energy source for micro-grids in remote and island regions.

However, as shown in the figure 9, it can be seen that electricity demand cannot be satisfied 100% due to the intermittent problem of CSP, which means that the ratio of CSP in the hybrid system must be reduced. Therefore, as a future study, the ratio of CSP will be reduced, and the hybrid system with the optimal ratio of CSP and MMR with the highest system efficiency will be studied.

ACKNOWLEDGEMENTS

This work was supported by the National Research Foundation of Korea (NRF) grant funded by the Korea government (MSIP) (2017M2B2B1071971)

REFERENCES

- [1] Kim, Seong Gu, et al. "A concept design of supercritical CO₂ cooled SMR operating at isolated microgrid region." *International Journal of Energy Research* 41.4 (2017): 512-525.
- [2] The 8th Basic Electricity Supply and Demand Plan of the Korea
- [3] Zhang, H. L., et al. "Concentrated solar power plants: Review and design methodology." *Renewable and sustainable energy reviews* 22 (2013): 466-481.
- [4] Ministry of Trade, Industry and Energy of Korea (2017), Study of optimal supply plan of electricity in power vulnerable region.
- [5] Bauer, Thomas, et al. "Material aspects of Solar Salt for sensible heat storage." *Applied energy* 111 (2013): 1114-1119
- [6] Ahn, Yoonhan, et al. "Review of supercritical CO₂ power cycle technology and current status of research and development." *Nuclear Engineering and Technology* 47.6 (2015): 647-661.
- [7] Rodriguez, Salvador B. *Advancing Molten Salts and Fuels at Sandia National Laboratories*. No. SAND-2017-10478R. Sandia National Laboratories (SNL-NM), 2017.
- [8] Le Moullec, Yann, et al. "Shouhang-EDF 10MWe supercritical CO₂ cycle CSP demonstration project." 3rd European Conference on Supercritical CO₂ (sCO₂) Power Systems 2019
- [9] Zitney, Stephen E., and Eric Liese. *Dynamic Modeling and Simulation of a 10MWe Supercritical CO₂ Recompression Closed Brayton Power Cycle for Off-Design, Part-Load, and Control Analysis*. No. NETL-PUB-21414. NETL, 2017
- [10] M.S.Kim, Y.H.Ahn, B.J.Kim, J.I.Lee, "Study on the supercritical CO₂ power cycles for landfill gas firing gas turbine bottoming cycle.", *Energy*, 111(2016), pp. 893-909
- [11] J.K. Lee, J.I. Lee, Y.H. Ahn and H.J. Y, *Design methodology of supercritical CO₂ brayton cycle turbomachineries*, ASME Turboexpo, Copenhagen, Denmark, 2012
- [12] Seungjoon Baik, Seong Gu Kim, Jekyoun Lee, Jeong Ik Lee, "Study on CO₂-water printed circuit heat exchanger performance operating under various CO₂ phases for S-CO₂ power cycle application", *Applied Thermal Engineering*, 2017.
- [13] Kwon, Jin Su, et al. "Development of accelerated PCHE off-design performance model for optimizing power system operation strategies in S-CO₂ Brayton cycle." *Applied Thermal Engineering* 159 (2019)